

MODELS "350SR & 350SRC"

Gravity Roller Conveyor

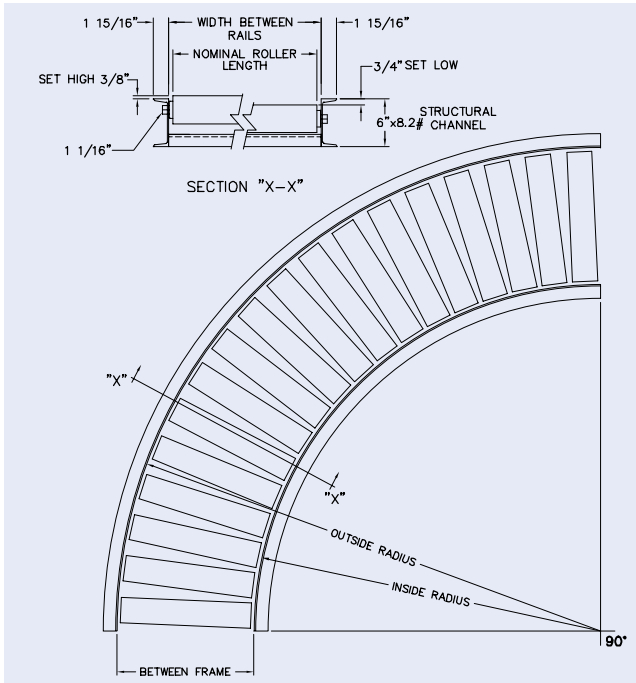

STANDARD SPECIFICATIONS

Frames - 6" x 8.2 pound structural steel channel with welded cross members painted. Rollers set $\frac{3}{8}$ " high.

Rollers - 3 $\frac{1}{2}$ " diameter x .30 wall with machined ends for press fit bearings.

Bearings - Labyrinth sealed and grease packed.

Axles - 1 $\frac{1}{16}$ " hex shaft, pinned.

Couplings - Butt type, for bolting frames together.

Widths - 7" between frames (B/F) and wider up to 51" between frames.

Length - 5' and 10' straight sections.

Capacity - 1300 pounds per roller, with 8400 pounds maximum distributed live load over 10 feet; 16,700 pounds maximum distributed live load over 5 feet lengths. All capacities are based on 4" centers.

Curve Degree - 45° and 90° with 4'0" inside radius only. Tapered rollers not available.

STRAIGHT SECTIONS - WEIGHTS

Nominal Roller Length	Width Between Frames	Model No.	Roller Centers (Inches)	10' Weight (lbs.)	5' Weight (lbs.)
6"	7"	350SR-7-4	4	468	236
		350SR-7-6	6	366	185
		350SR-7-8	8	315	160
		350SR-7-12	12	264	134
10"	11"	350SR-11-4	4	611	315
		350SR-11-6	6	464	234
		350SR-11-8	8	390	204
		350SR-11-12	12	317	168
14"	15"	350SR-15-4	4	755	387
		350SR-15-6	6	563	291
		350SR-15-8	8	466	242
		350SR-15-12	12	370	194
18"	19"	350SR-19-4	4	899	454
		350SR-19-6	6	661	332
		350SR-19-8	8	542	273
		350SR-19-12	12	423	214
22"	23"	350SR-23-4	4	1042	523
		350SR-23-6	6	759	383
		350SR-23-8	8	617	311
		350SR-23-12	12	476	240
26"	27"	350SR-27-4	4	1185	595
		350SR-27-6	6	857	431
		350SR-27-8	8	693	349
		350SR-27-12	12	529	267
30"	31"	350SR-31-4	4	1329	677
		350SR-31-6	6	955	480
		350SR-31-8	8	769	397
		350SR-31-12	12	582	293
34"	35"	350SR-35-4	4	1472	736
		350SR-35-6	6	1053	529
		350SR-35-8	8	844	424
		350SR-35-12	12	634	319
38"	39"	350SR-39-4	4	1615	810
		350SR-39-6	6	1151	578
		350SR-39-8	8	919	462
		350SR-39-12	12	687	346
42"	43"	350SR-43-4	4	1759	892
		350SR-43-6	6	1250	627
		350SR-43-8	8	994	500
		350SR-43-12	12	741	373
46"	47"	350SR-47-4	4	1903	954
		350SR-47-6	6	1348	676
		350SR-47-8	8	1071	538
		350SR-47-12	12	795	399
50"	51"	350SR-51-4	4	2045	1025
		350SR-51-6	6	1446	727
		350SR-51-8	8	1147	575
		350SR-51-12	12	846	425

CURVED SECTIONS - WEIGHTS

	Nominal Roller Length*	Width Between Frames	Model No. (for 90°)	90° Weight (lbs.)	45° Weight (lbs.)
18 Rollers per 90° Curve	6"	7"	350SRC-7-90S	328	165
	10"	11"	350SRC-11-90S	428	220
	14"	15"	350SRC-15-90S	529	270
	18"	19"	350SRC-19-90S	630	318
	22"	23"	350SRC-23-90S	729	366
	26"	27"	350SRC-27-90S	830	417
	30"	31"	350SRC-31-90S	930	474
	34"	35"	350SRC-35-90S	1030	515
	38"	39"	350SRC-39-90S	1131	567
	42"	43"	350SRC-43-90S	1231	625
	46"	47"	350SRC-47-90S	1332	668
50"	51"	350SRC-51-90S	1432	718	

*4'0" Inside Radius only.